



Incognito/i.am Table Base System

Tables / Table Base Systems

Incognito/i.am Table Base System

Incognito and i.am are totally flexible and versatile table bases that provide a complete family of product options for the commercial environment.

THE INCOGNITO Base



- ▶ The Incognito Base features a polished aluminium foot with a silver crystallized effect on the internal cavity. The frame comes in a black powder coated finish.

THE TRAPEZE Base



- ▶ The Trapeze base is modern design. The standard finish is a chrome foot set against a black powder coated steel frame.

THE I.AM Base



- ▶ The i.am base is modern yet classic. The standard finish is a chrome foot set against a black powder coated steel frame.

THE RECTANGULAR Table Base

The Incognito and i.am Rectangular Table Bases are modern pedestal leg systems that are both simple and effective in appearance. The Incognito and i.am bases are a perfect solution for smaller boardroom tables.

Both Rectangular Base options are available in two different foot sizes, to suit tables of various widths.

► MODEL 850

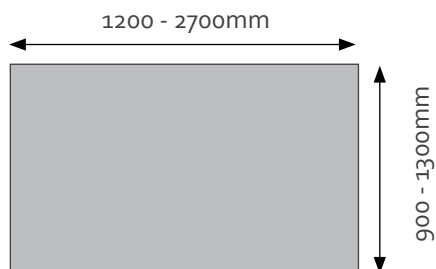

Incognito Rectangular Base

► MODEL 600

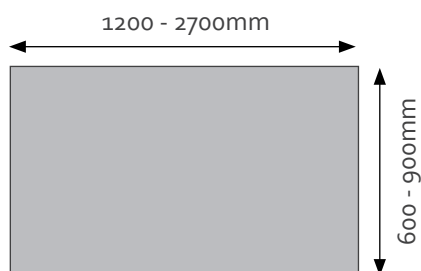

i.am Rectangular Base

Incognito/i.am Table Base System

THE MULTI LEG Table Base

The Incognito Multi Leg Base is designed to suit larger boardroom tables. By adding frame spacers, legs and feet, the table length options become unlimited. This allows the user to create a top size purely to suit their own requirements.

► MODEL MULTI LEG TABLE BASE

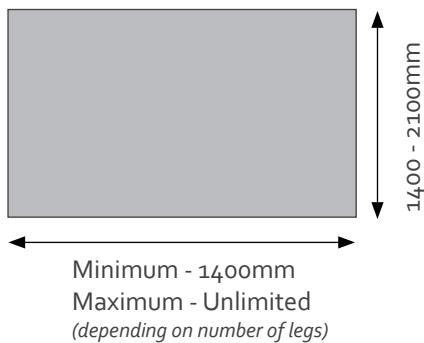

Incognito Multi Leg Base



Trapeze Multi Leg Base

FOLDING Table Bases

The Incognito Folding Table and i.am Turn Folding Table work in conjunction with the rest of the Incognito and i.am systems, similar in aesthetic properties and style.

Suitable for hot-desking, breakout areas and offices that require constant change, the folding tables can quickly and easily be tilted, moved or stored.

► MODEL FOLDING TABLE - Incognito

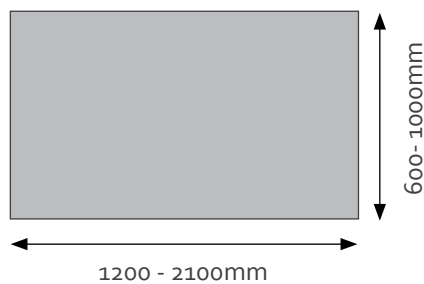

Incognito Folding Base

► MODEL FOLDING TABLE - i.am

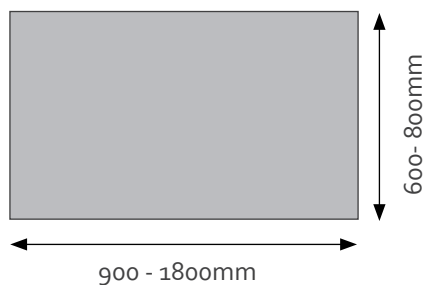

i.am Folding Base

Incognito/i.am Table Base System

ROUND Table Bases

Incognito and i.am will accommodate circular and oval table tops using matching components that are used for desks and tables. This allows for uniformity throughout the work environment and complete flexibility of design.

► MODEL 4 STAR

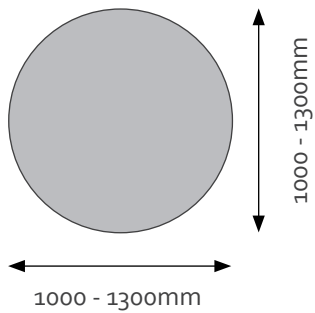

Incognito 4 Star Base

► MODEL 5 STAR

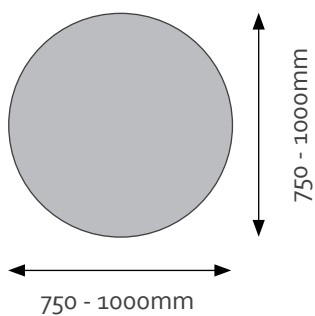

i.am 5 Star Base

MULTI LEG Round Base

Incognito and i.am Multi Leg Bases are 4 star, 4 pole bases suitable for larger round tops. The solid structure of the legs and feet create a sturdy round meeting table which provides plenty of leg space for the user.

► MODEL MULTI LEG ROUND

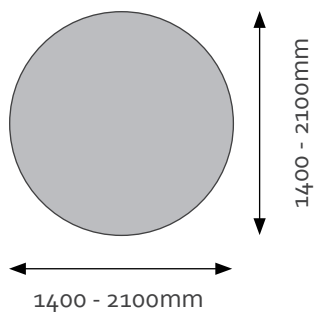

Incognito Round Multi Leg Base



i.am Round Multi Leg Base

ENVIRONMENTAL Policy

Montage Interiors aims to achieve best practice of environmental sustainability, not only across our product range, but also as an organisation. In order to attain this we recycle all manufacturing wastes and manufacture with environmentally sustainable and friendly products, where possible. This is also undertaken alongside our clients, to ensure you are provided with the best furniture system possible. All waste products are recycled, reused or disposed of in a responsible manner. We endeavour to use recycled eco panels, sustainable timbers with low or zero emissions, and water based products in favour of solvents, during manufacture.

Extended warranties on many of our core products, reconfigurable workstation systems, plus a buy back/ recycling policy on many items, demonstrates our commitment to Environmentally Sustainable Design (ESD) and Product Stewardship.

